

iceFUN iCE40 HX8K module

IceFUN Connections

Pin pitch 0.1" with rows are on a 0.8" pitch.
Suitable for use on solderless breadboards.

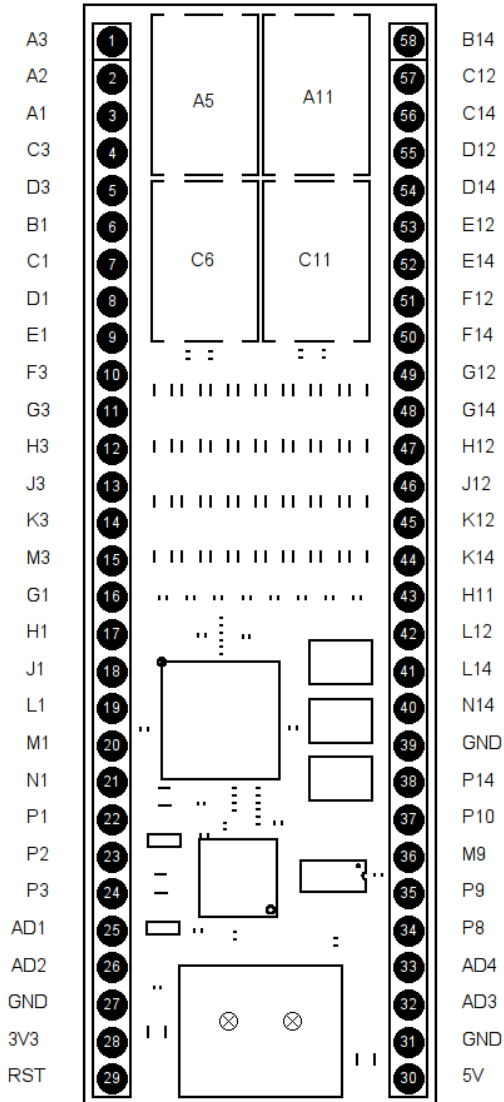

Push Buttons

With on-board pull-up resistors, Low when pressed
Pins A5 A11 C6 C11

LED Matrix Connections

Leds are (left to right)
Led7 Led6 Led5 Led4 Led3 Led2 Led1 Led0
C4 A4 C7 A7 D6 D7 A10 C10
Drive low to light LED.

Led row drives are (top to bottom)
C5
A6
D10
A12
Drive low to light LED row.

High Current RGB drivers

Up to 3 Amp total current.

L14
N14
GND
P14

Designed for 12v LED strips. You MUST use the GND pin between P14 and N14 for the return ground (0v).

Piezo Speaker

Two pins drive the on-board piezo speaker.
M12 M6

Oscillator

An on-board 12MHz oscillator feeds pin P7 (GBIN5).

10-bit A/D converters

Accessed via serial commands to PIC CPU
250k baud, 1 start, 8 data, 1 stop, no parity
Tx on in P4, Rx on pin P5

X1 - send command 0xA1
X2 - 0xA2
X3 - 0xA3
X4 - 0xA4

Receive 2 bytes, high byte first. Combine for 10 bit right justified result.

8Mb (1MB) SPI Flash

CS - P13
SCK - P12
SDI - P11 (SDO on flash chip)
SDO - M11 (SDI on flash chip)
First three 64k sectors reserved for FPGA configuration.

The iceFUN module is powered from USB or an external 5v supply. There are on-board 3.3v and 1.2v regulators. All PIC and FPGA I/O pins are 3.3v, do not connect these to 5v devices.

IceFun is programmed using iceFUNprog.

Linux users can download the source from our github at <https://github.com/devantech/iceFUNprog>

A Windows version (.exe and c# source) is available at from www.robot-electronics.co.uk/files/iceFUNprog.zip

Any toolchain which generates a binary bit-stream may be used, such as lattice iCEcube2.

Linux users also have the icestorm tools with Yosys and NextPnr. <http://www.clifford.at/icestorm/>

Verilog examples may be found at <https://github.com/devantech/iceFUN>

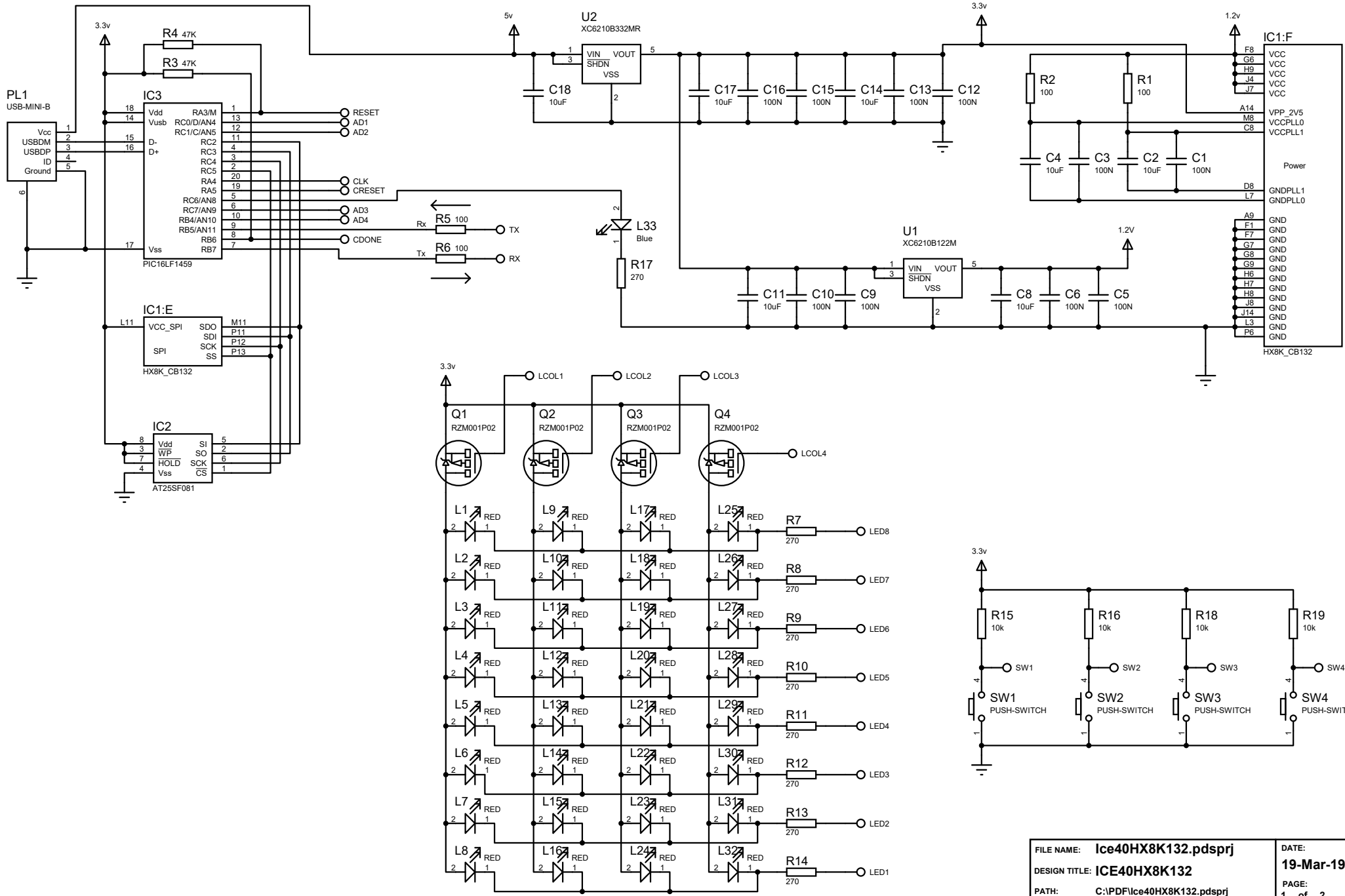

FILE NAME:	Ice40HX8K132.pdsprj	DATE:	19-Mar-19
DESIGN TITLE:	ICE40HX8K132	PAGE:	1 of 2
PATH:	C:\PDF\Ice40HX8K132.pdsprj	BY:	Devantech Ltd.
	REV: 2	TIME:	10:17:51

